



www.bitseiki.com

 **Compact Mechanical Design**
Double Profit and Efficiency

 **Twin-spindle**

 **Single-spindle**

Machining Efficiency

Labour Cost

Robot

Space for Factory

Energy Saving



MTS-600 . MTS-5A VERTICAL MACHINING CENTER
Twin Spindle Twin Magazine

LTS-280 SLANT BED CNC LATHE
Twin Spindle, Single Turret, Double Tool Holders



BAIZHENG INNOVATION TECHNOLOGY CO.,LTD.

 +886-4-2529-3598  +886-4-2529-3866  baizheng@bitseiki.com  No. 372, Fengzhou Rd., Shengang Dist., Taichung City 42945, Taiwan

BITSEIKI
BAIZHENG INNOVATION TECHNOLOGY CO.,LTD.

INNOVATIVE INVENTION

DOUBLE EFFICIENCY DESIGN

Twin spindle tool can independence compensation.

Patented

twin-spindle CNC milling machine

Taiwan 1586463

USA 9610668

China 201720114824.0

Germany 202018100217

MTS-600 · MTS-5A

VERTICAL MACHINING CENTER Twin Spindle Twin Magazine

The **MTS-600** vertical machining center is specially designed with twin spindle and twin magazine (Enclosed cover disk type). It not only creates double machining efficiency and double throughput, but also helps customer to save significant investment costs of machine and labor requirement. In today's competitive business environment, **MTS-600 · MTS-5A** is your right choice for creating competitiveness.

Double spindle
Headstock

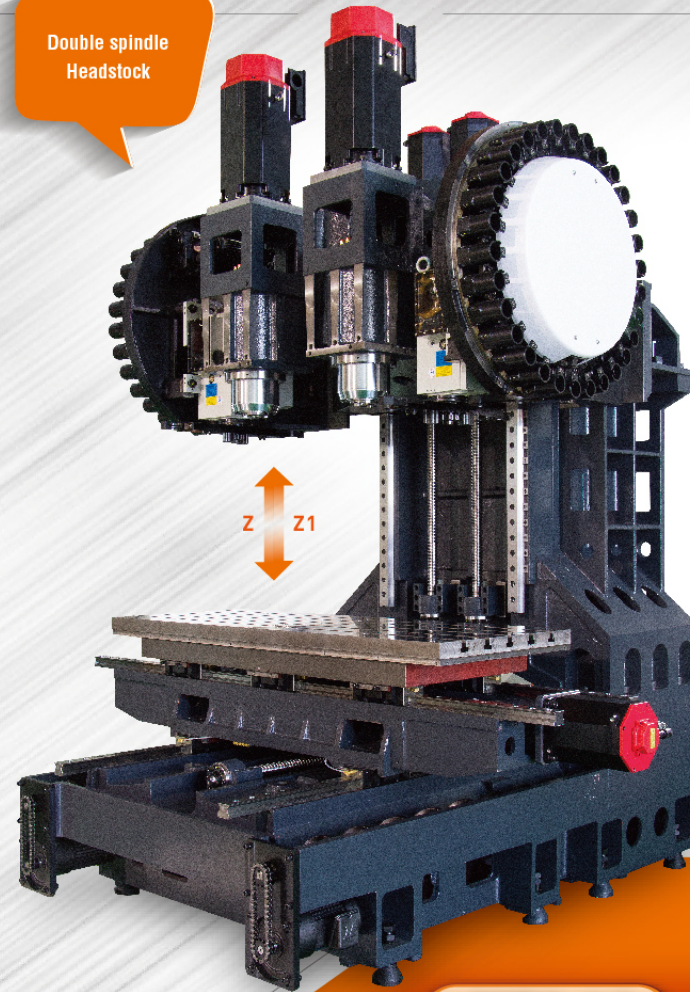

TWIN SPINDLE HEADS

- Twin spindles are directly driven by servo motors. (No counterweight)
- Twin spindles can be operated simultaneously.
- Twin spindle can perform tool offset.
- Highly rigid machine structure
- The structural parts of the machine are manufactured from high quality cast iron, featuring high rigidity and no deformation.

MTS-600

Table size

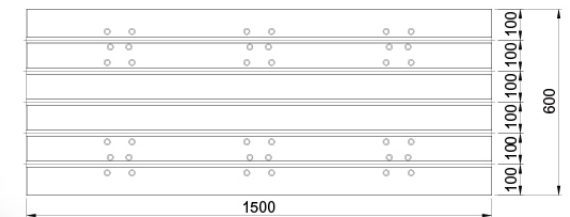

Width of T-slot T

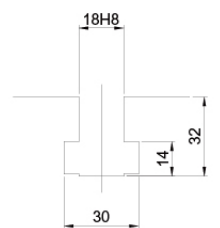

MTS-5A

- Double servo with swing axis
- Driven by non-backlash roller cam

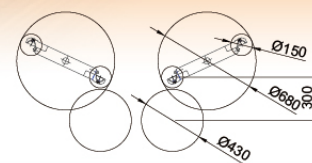

Tool Interference Diagram

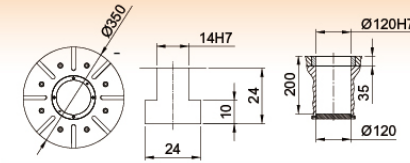

Center-hole diameter

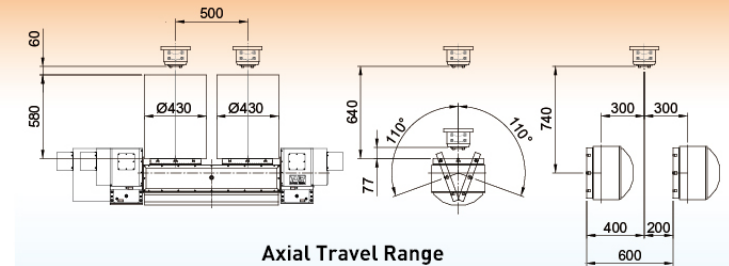

Axial Travel Range

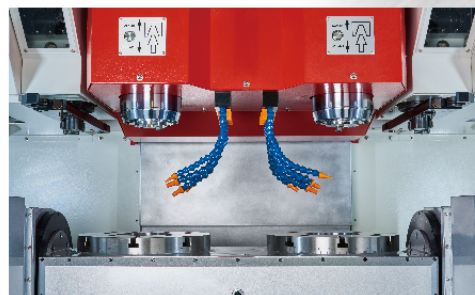

Twin 5-axis

- Twin Spindle
- Twin Magazine
- Double efficiency

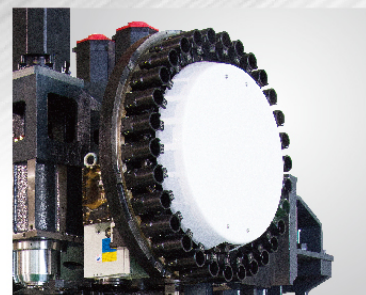

Disk type

- Fast tool change
- T to T 1.5sec with arm type
- The magazine is designed with frequency inverted brake without parts wearing problem.
- Heavy tools are changed horizontally at a low speed for safety.



Touch screen (Opt.)

- Malfunction display
- For reading operation instructions
- Current machining status monitoring function(optional)
- High expandability makes it suitable for flexible machining system.

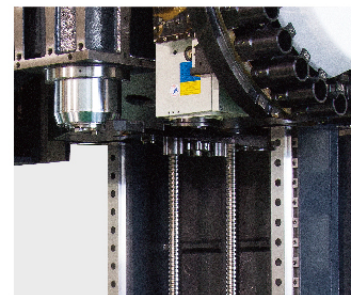

Roller type linear ways on 3 axes

The X,Y,Z-axis are all mounted with #45 roller type linear ways, featuring outstanding loading capacity and fast and smooth feed.

Spindle motor rated output

Rated output

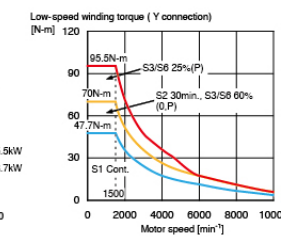
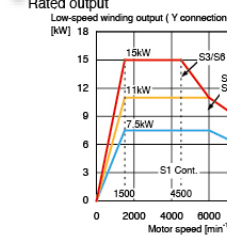

High-speed winding output (A connection)

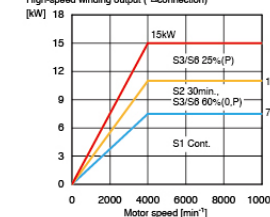

High-speed winding torque (A connection)

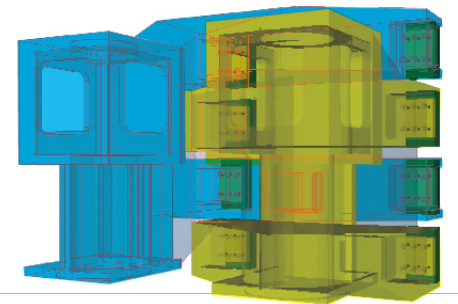
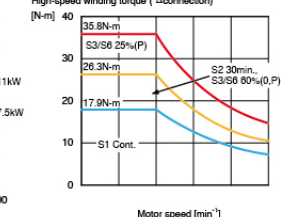

Design Patent

Spindle heads cross large span

The patented crossover design of the spindle heads, realizes the large span of the column rail and increases the geometrical rigidity of the structure.

LTS-280

SLANT BED CNC LATHE

Twin Spindle, Single Turret, Double Tool Holders

High Speed Machining! Double Efficiency!
Main and sub-spindle perform machining synchronously,
resulting in double machining efficiency.

Patented
twin-spindle CNC lathe
Taiwan 1642498
USA 16186612
China 201721817115
China 201711405816.2
India 201814043476
Turkey 2018/019674
Japan 2018-209689
Korea 10-2018-0143455

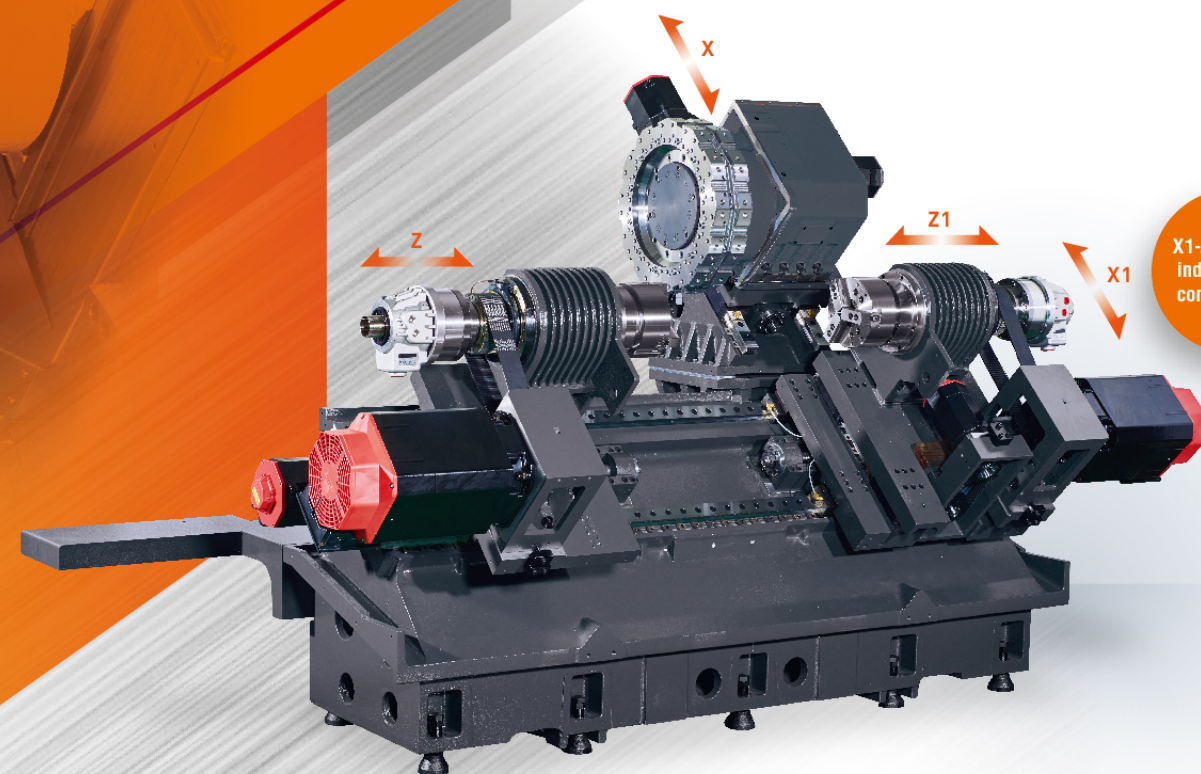

X1-Axis Travel
Independence
compensation

- 12-position servo turret can be loaded with 24 tools.
- Servo turret provides fast tool change.
- 45° slant bed structure features high rigidity and convenient chip exhaust.
- X, Z-axis are mounted with #45 roller type linear guide ways with outstanding heavy load resistance capacity.
- Tool length and tool diameter offset can be performed on X, Z-axis.
- X1-axis provides tool diameter offset on the sub-spindle.
- Main and sub-spindle are fitted with Ø8" hydraulic 3-jaw chucks.
- Fully enclosed splash guard.

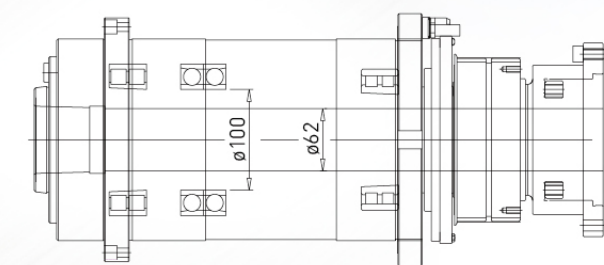

High-precision spindle

- The spindle bearings are precision double-row roller bearings and high-speed precision angled ball bearings.
- With the heat sink spindle head design, it can effectively reduce the spindle temperature
- Maximum stability and bearing life when during the cutting

Tool system

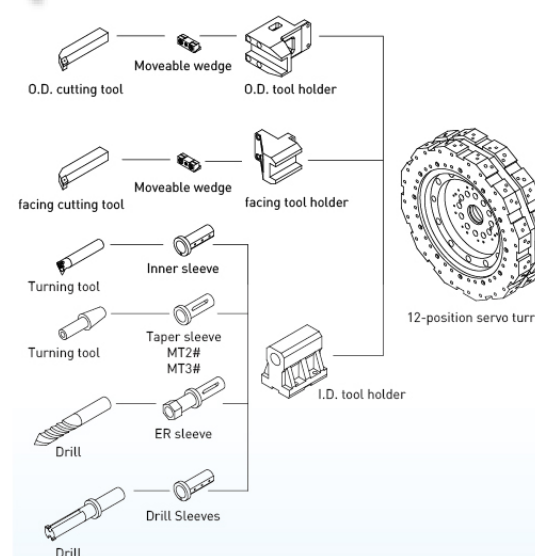

Axial Travel Range

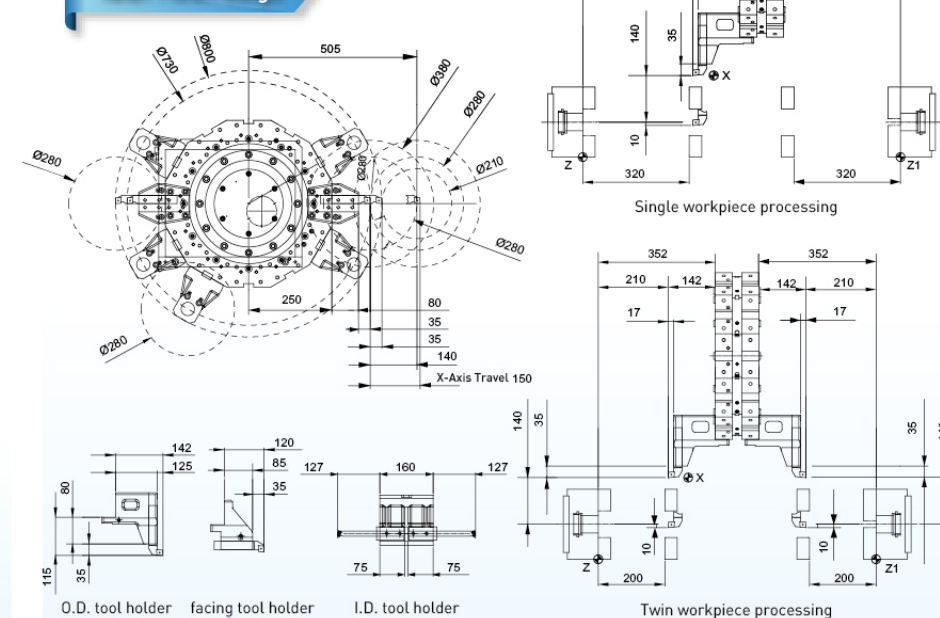

Opposite twin turrets

- Twin spindle
- Allows for simultaneous or independent machining

Spindle motor rated output

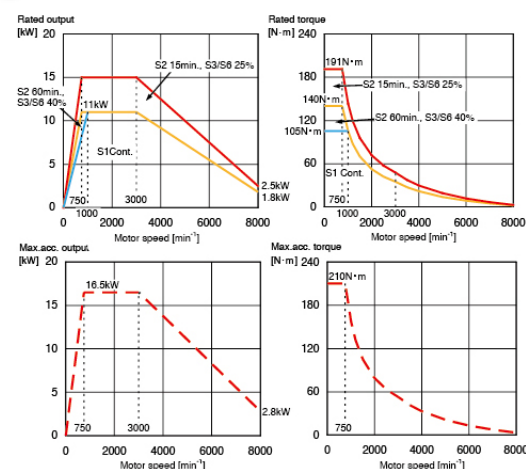

MTS-600	
SPINDLE	
Spindle Speed	10000rpm
Spindle Motor Power	7.5~11 kw
Spindle Taper	BT40
Distance Between Spindles	500mm
Inside Diameter Of Spindle Bearing	ø70
TRAVEL	
X-axis Travel	500mm
Y-axis Travel	600mm
Z/Z1-axis Travel	570mm
Spindle Nose to Table Surface	100~670mm
TABLE	
Table Sizes	1500x600mm
T-Slots (No.XWXP)	5x18x100
Max. Table Load	700kg
FEED	
Rapid Traverse Rates On X/Y/Z/Z1-axis	36 / 36 / 3 0 / 30 m/min
Cutting Feed Rate	1~20000 mm/min
Servo Motor Power On X/Y/Z/Z1-axis	4 / 4 / 7 / 7 kw
Ball Screw Specification	ø40 * P12
Linear Guide Way Specification	45mm
AUTO TOOL CHANGER	
No. Of Tools	24+1T(30+1T)
Tool Weight	7kg
Max. Tool Size	ø75
Max. Tool Size (without adjacent tool)	ø150
Max. Tool Length	300mm
Tool Change Method	Arm Type
Tool Selection	Random Memory
Tool Change Time (T-T)	1.5 sec
MACHINE DIMENSIONS / WEIGHT / OTHERS	
Space Occupied	3650(W) x 3520(D) x 3000(H)mm
Net Weight Of Machine	8400kg
Air Pressure Required	7kg/cm2
Power Source Required	45KVA

MTS-5A	
SPINDLE	
Spindle Speed	10000rpm
Spindle Motor Power	7.5~11 kw
Spindle Taper	BT40
Distance Between Spindles	500mm
Inside Diameter Of Spindle Bearing	ø70
TRAVEL	
X-axis Travel	500mm
Y-axis Travel	600mm
Z/Z1-axis Travel	570mm
A-axis Travel	±110°
C-axis Travel	360°
Spindle Nose to Table Surface	70~640mm
TABLE	
Table Sizes	ψ350mm (Single Disk) * 2
T-Slots (No.xW)	8X14 (Single Disk) * 2
Max. Table Load	150kg(Single Disk) * 2
Allowable Max. Cutting Force (when A, C-axis is Clamped)	Disk Surface Positive Force 1800 kg Disk Surface Axial Force 230kg-m Disk Surface Radial Force 115kg-m Allowable Cutting Torque 80kg-m
A, C-axis Max. Locking Force	230/115kg-m
FEED	
Rapid Traverse Rates On X/Y/Z/Z1-axis	36 / 36 / 30 / 30 m/min
Max. Speed On A, C-axis	16.6/25 rpm
Cutting Feed Rate	1~20000 mm/min
Servo Motor Power On X/Y/Z/Z1/A/C-axis	4 / 4 / 7 / 7 / 2.7 X 2 / 3 kw
Ball Screw Specification	ø40 * P12
Linear Guide Way Specification	45mm
AUTO TOOL CHANGER	
No. Of Tools	24+1T (30+1T)
Tool Weight	7kg
Max. Tool Size	ø75
Max. Tool Size (without adjacent tool)	ø150
Max. Tool Length	300mm
Tool Change Method	Arm Type
Tool Selection	Random Memory
Tool Change Time (T-T)	1.5 sec
MACHINE DIMENSIONS / WEIGHT / OTHERS	
Space Occupied	3650(W) x 3520(D) x 3350(H)mm
Net Weight Of Machine	9500kg
Air Pressure Required	7kg/cm2
Power Source Required	50KVA

STANDARD EQUIPMENT	
Tool Box	Leveing Blocks / Bolts
Working Lamp / Fluorescent Lamp / Warning Lamp	Machine/Electric Control Operation Manual / Heat Exchanger
Coolant System	Chip Auger
Fully Enclosed Splash Guard	Air Gun
Spindle Air Blast	Coolant Gun
Air Curtain For Spindle	Swiveling Operation Box
Coolant Jets Around Spindle	MPG Hand Wheel
Spindle Side Coolant	USB Transfer
Spindle Side Air Blast	CF Card Transfer
Automatic Lubrication System	RS232
Guard on 3 Axes	Auto Power Off

OPTIONAL EQUIPMENT	
Safety Door Lock	Oil Mist Coolant System
CE	Column Raised by 300mm (MTS-600 only)
Automatic Front Door	Oil Fluid Separator
Linear Scale	Touch Screen
Spindle Oil Cooler	
Oil Mist Collector	
Coolant Through Spindle (20~70bar)	
Coolant Through Tool Holder	
Chip Conveyor	
4th-axis Rotary Table	
Tool Length Measurement Device	
Workpiece Measurement Device	

LTS-280	
SPINDLE	
Spindle Speed	4200rpm
Spindle Chuck	A2-6 (8")
Spindle Nose Taper	1/20
Spindle Motor Power	11~15kw
Inside diameter of spindle bearing	ø100
MACHINING CAPACITY	
Swing Over Bed (Single-spindle)	ø520
Standard Turning Diameter	ø210
Max. Turning Diameter	ø280
Bar Capacity	ø51
Max. Turning length (Twin Workpiece)	200mm
Max. Turning length (Single Workpiece)	320mm
TRAVELL	
X-Axis Travel	140+10mm
Z / Z1-Axis Travel (Twin workpiece)	200mm
Z / Z1-Axis Travel (Single workpiece)	320mm
X1-Axis Travel (independence compensation)	±10mm
FEED	
Rapid Traverse Rates On X, Z, Z1-axis	30m/min
Cutting Feed Rate	1~1260 mm/min
Servo Motor Power On X, Z, Z1, X1-axis	3 / 3 / 3 / 1.8 kw
Ball Screw Specification	ø40 * P10
Linear Guide Way Specification	45mm

AUTO TOOL CHANGER	
No. Of Tools	12T
O.D Tool Shank Szie	□25
Max. I.D Tool Shank Diameter	ø40
Tool Disk Thickness	130mm
Tool Change Time (Adjacent Tool)	0.2sec
Tool Change Time (Opposite Tool)	0.5sec
MACHINE DIMENSIONS / WEIGHT / OTHERS	
Space Occupied	4550(W) x 2850(D) x 2200(H)mm
Net Weight Of Machine	6500kg
Air Pressure Required	7kg/cm2
Power Source Required	40KVA

STANDARD EQUIPMENT	
Tool Box	Machine/Electric Control
Working Lamp / Fluorescent Lamp / Warning Lamp	Operation Manual / Heat Exchanger
Coolant System	Chip Auger
Fully Enclosed Splash Guard	Air Gun
Hydraulic Chuck & Soft Jaws	Coolant Gun
Chip Conveyor	Swiveling Operation Box
Tool Holder	MPG Hand Wheel
Automatic Lubrication System	USB Transfer
Guard On Axes	CF Card Transfer
Leveing Blocks / Bolts	Auto Power Off

OPTIONAL EQUIPMENT	
Safety Door Lock	Oil Fluid Separator
CE	Tool Length Measurement Device
Automatic Front Door	Hard Jaws
Linear Sacle	Touch Screen
Oil Mist Collector	

Dimensions

